

M6 THREAD THROUGH.
CBORE ϕ 6 X 2 DEEP
TYP 4

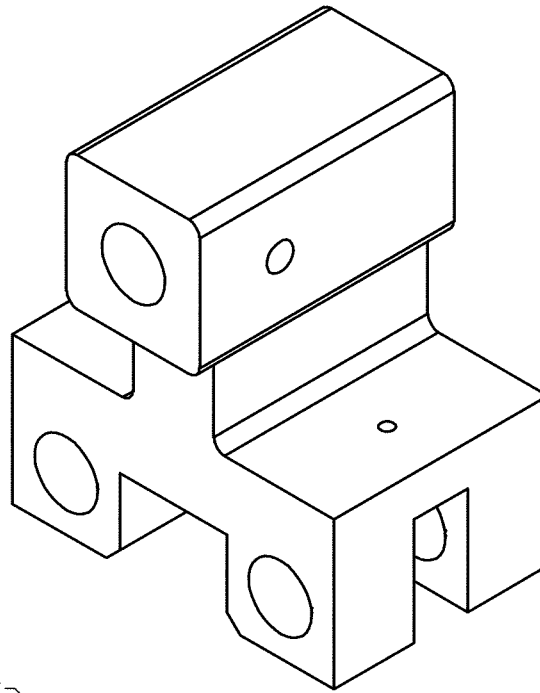

ϕ 24^{+0.02}₀ THROUGH.

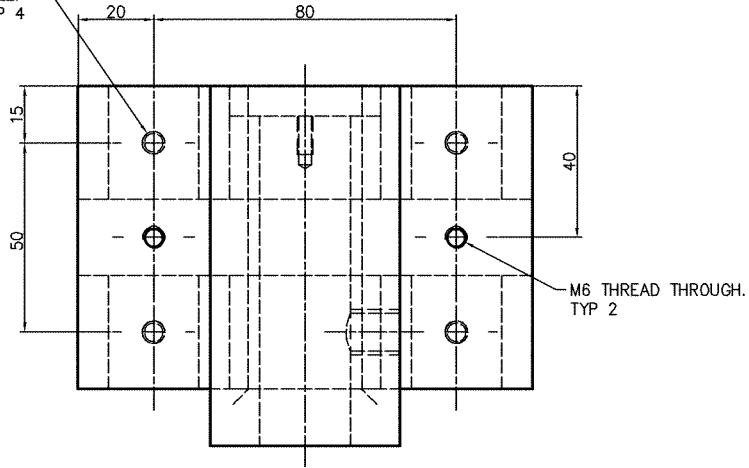
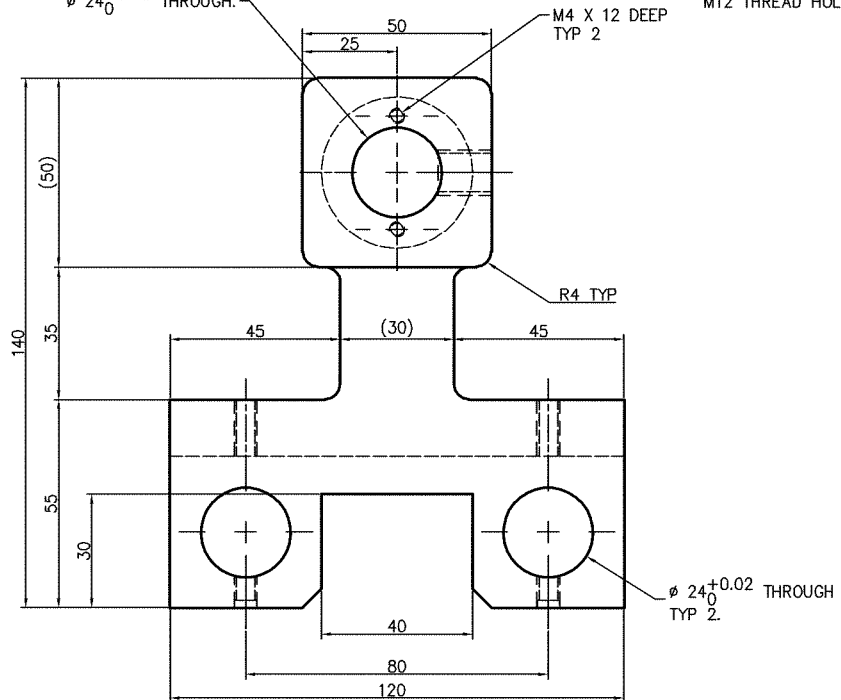

M12 THREAD HOLE

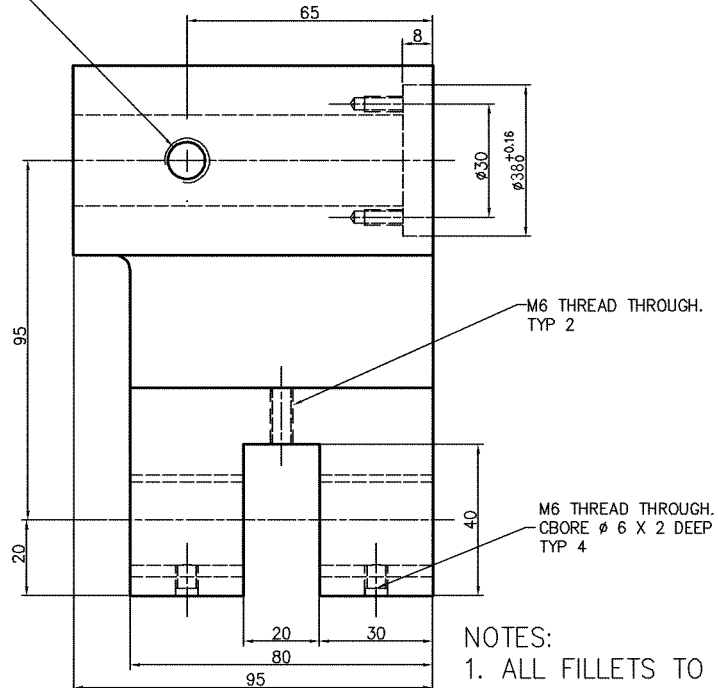

NOTES:

1. ALL FILLETS TO BE R4.
2. ALL CHAMFERS TO BE 5 X 45°

TITLE:	MINI LATHE
PART-NAME:	TAILSTOCK
DRN NO:	LA030100
DRN BY:	
DATE:	02-2001
FILE:	TAILSTOCK.DWG
REV NO:	C
REV BY:	
DATE:	08-2001
FINISH:	
MATL:	CAST ALUMINUM
SCALE:	1:2
DO NOT SCALE DRAWING	
PROJECTION	
GENERAL MACHINING TOLERANCE	
.X \pm 0.20	
.XX \pm 0.05	
0 TO 250 \pm 0.5	
500 & ABOVE \pm 2.0	
TIR \pm 0.20	
ANGULAR \pm 1/4°	
THE HONG KONG POLYTECHNIC UNIVERSITY INDUSTRIAL CENTRE	

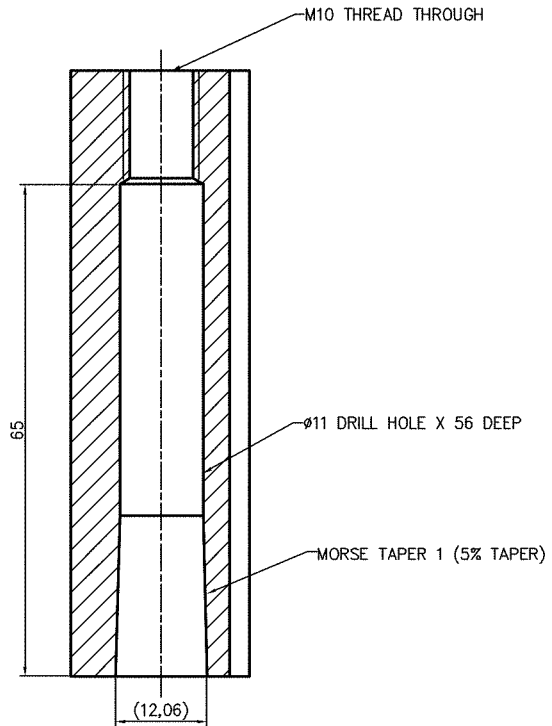

SECTION A-A

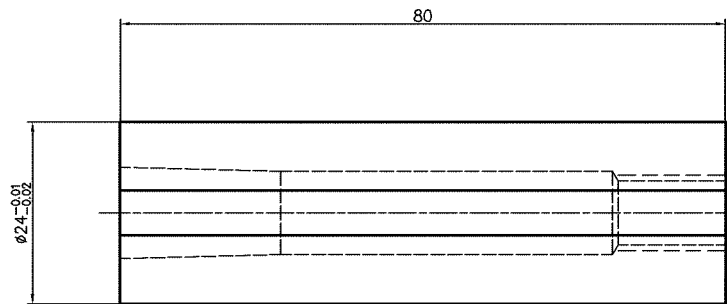
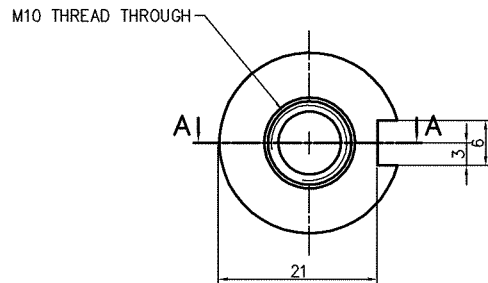
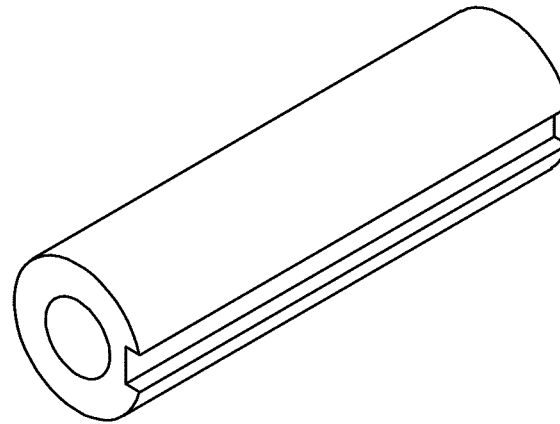

TITLE:
MINI LATHE
PART-NAME:
TAILSTOCK SPINDLE

DRN NO: LA030200

DRN BY:

DATE: 02-2001

FILE: TAILSTOCK.DWG

REV NO: B

REV BY:

DATE: 05-2001

FINISH:

MATL: **M CARBON STEEL**

SCALE: 1:1

DO NOT SCALE DRAWING

PROJECTION

GENERAL MACHINING TOLERANCE

.X ± 0.20
.XX ± 0.05
0T0250 ± 0.5
500&ABOVE ± 2.0
TIR ± 0.20
ANGULAR ± 1/4'



THE HONG KONG
POLYTECHNIC UNIVERSITY
INDUSTRIAL CENTRE

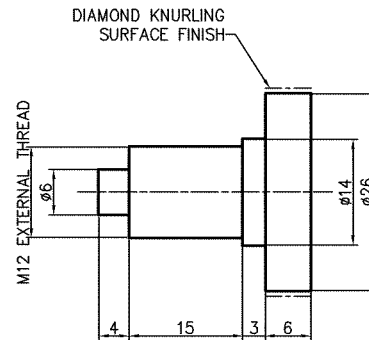
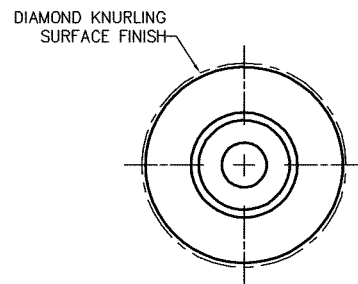
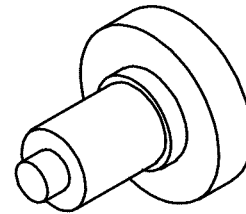

TITLE:
MINI LATHE
PART-NAME:
SPINDLE LOCK SCREW

DRN NO: LA030300

DRN BY:

DATE: 02-2001

FILE: TAILSTOCK.DWG

REV NO: C

REV BY:

DATE: 08-2001

FINISH:

MATL: M CARBON STEEL

SCALE: 1:1

DO NOT SCALE DRAWING

PROJECTION 

GENERAL MACHINING TOLERANCE
.X \pm 0.20
.XX \pm 0.05
0T0250 \pm 0.5
500&ABOVE \pm 2.0
TIR \pm 0.20
ANGULAR \pm 1/4'



THE HONG KONG
POLYTECHNIC UNIVERSITY
INDUSTRIAL CENTRE

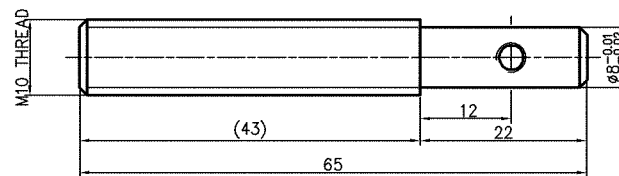
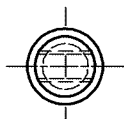
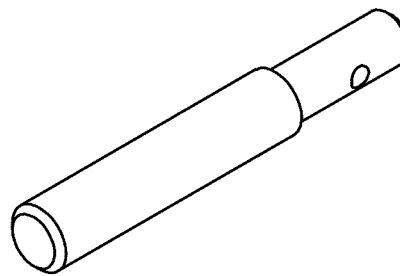
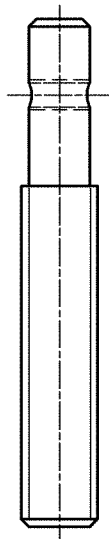

TITLE:
MINI LATHE
PART-NAME:
TAILSTOCK FEEDSCREW

DRN NO: LA030400

DRN BY:

DATE: 02-2001

FILE: TAILSTOCK.DWG

REV NO: C

REV BY:

DATE: 08-2001

FINISH:

MATL: S.S.

SCALE: 1:1

DO NOT SCALE DRAWING

PROJECTION

GENERAL MACHINING TOLERANCE

.X ± 0.20
.XX ± 0.05
0T0250 ± 0.5
500&ABOVE ± 2.0
TIR ± 0.20
ANGULAR $\pm 1/4^\circ$



THE HONG KONG
POLYTECHNIC UNIVERSITY
INDUSTRIAL CENTRE

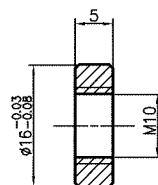
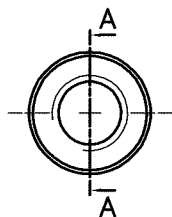

SECTION A-A

NOTES:

1. ALL CHAMFERS TO BE 0.5 X 45

TITLE:
MINI LATHE
PART-NAME:
LEAD SCREW RING

DRN NO: LA120100

DRN BY:

DATE: 02-2001

FILE: TAILSTOCK.DWG

REV NO: B

REV BY:

DATE: 05-2001

FINISH:

MATL: S.S.

SCALE: 1:1

DO NOT SCALE DRAWING

PROJECTION

GENERAL MACHINING TOLERANCE
.X \pm 0.20
.XX \pm 0.05
0T0250 \pm 0.5
500&ABOVE \pm 2.0
TIR \pm 0.20
ANGULAR \pm 1/4'



THE HONG KONG
POLYTECHNIC UNIVERSITY
INDUSTRIAL CENTRE

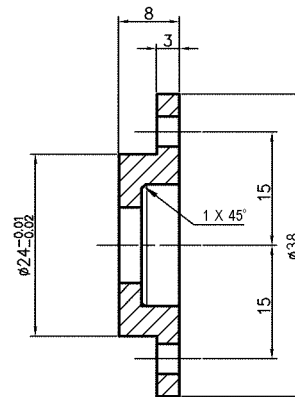
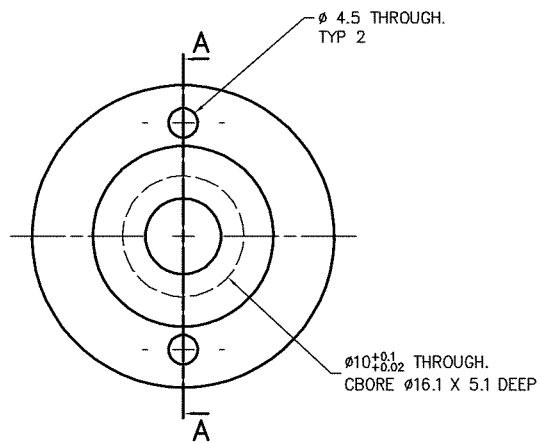
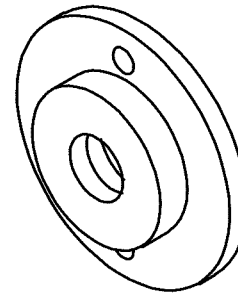

SECTION A-A

TITLE:
 MINI LATHE
 PART-NAME:
 FEEDSCREW HOUSING

DRN NO: LA030500

DRN BY:

DATE: 02-2001

FILE: TAILSTOCK.DWG

REV NO: D

REV BY:

DATE: 08-2001

FINISH:

MATL: BRONZE

SCALE: 1:1

DO NOT SCALE DRAWING

PROJECTION

GENERAL MACHINING TOLERANCE
 .X ± 0.20
 .XX ± 0.05
 0T0250 ± 0.5
 500&ABOVE ± 2.0
 TIR ± 0.20
 ANGULAR $\pm 1/4'$



THE HONG KONG
 POLYTECHNIC UNIVERSITY
 INDUSTRIAL CENTRE

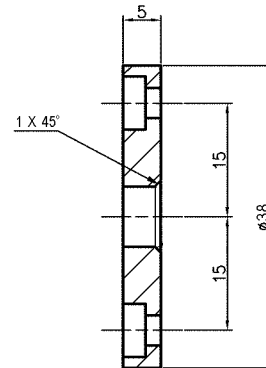
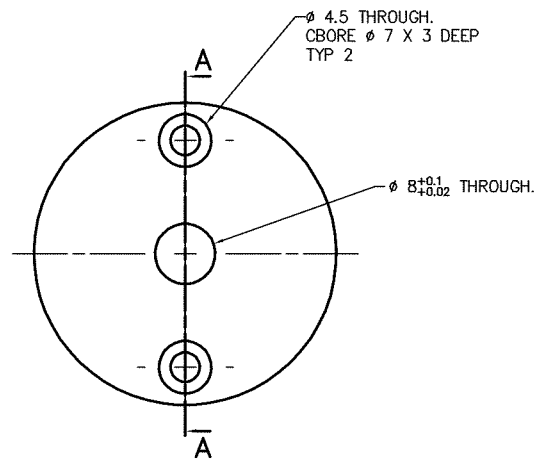
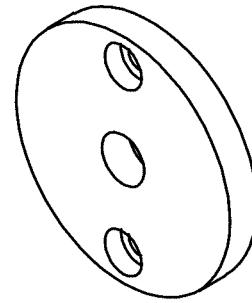

SECTION A-A

TITLE:
 MINI LATHE
 PART-NAME:
 FEEDSCREW COVER PLATE

DRN NO: LA030600

DRN BY:

DATE: 02-2001

FILE: TAILSTOCK.DWG

REV NO: D

REV BY:

DATE: 08-2001

FINISH:

MATL: BRONZE

SCALE: 1:1

DO NOT SCALE DRAWING

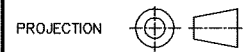

GENERAL MACHINING TOLERANCE

.X \pm 0.20
 .XX \pm 0.05
 0T0250 \pm 0.5
 500&ABOVE \pm 2.0
 TIR \pm 0.20
 ANGULAR \pm 1/4°



THE HONG KONG
 POLYTECHNIC UNIVERSITY
 INDUSTRIAL CENTRE

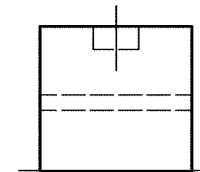
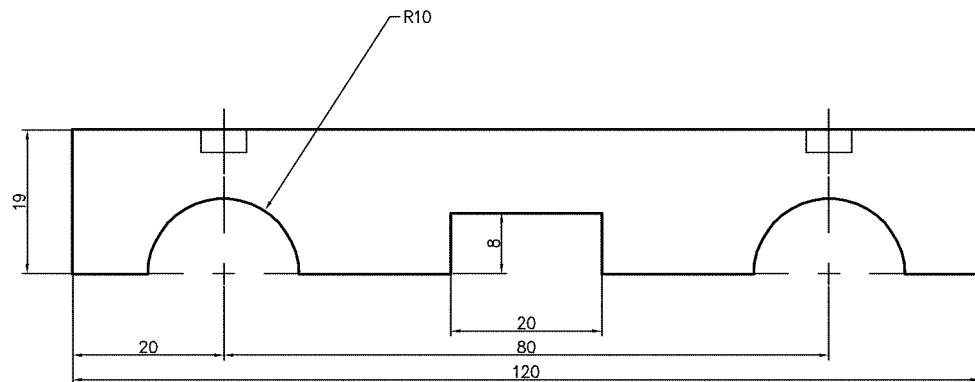
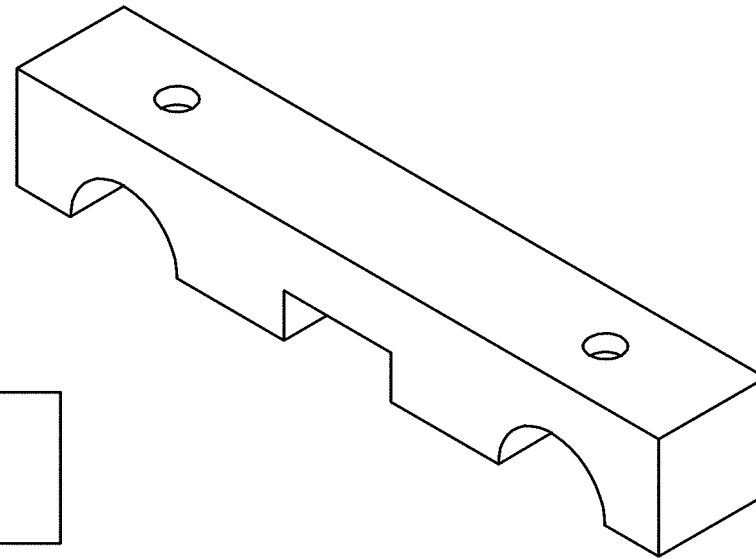
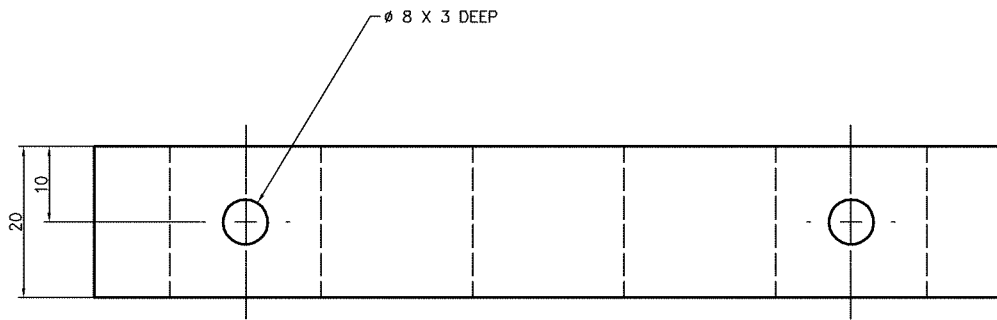

TITLE:	MINI LATHE
PART-NAME:	TAILSTOCK GRIP
DRN NO:	LA030700
DRN BY:	
DATE:	02-2001
FILE:	TAILSTOCK.DWG
REV NO:	B
REV BY:	
DATE:	08-2001
FINISH:	
MATL:	COPPER
SCALE:	1:1
DO NOT SCALE DRAWING	



GENERAL MACHINING TOLERANCE
.X ± 0.20
.XX ± 0.05
0T0250 ± 0.5
500&ABOVE ± 2.0
TIR ± 0.20
ANGULAR $\pm 1/4^\circ$



THE HONG KONG
POLYTECHNIC UNIVERSITY
INDUSTRIAL CENTRE

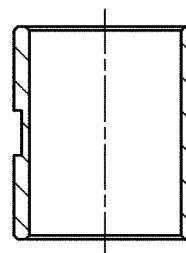
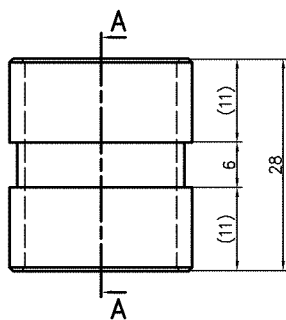
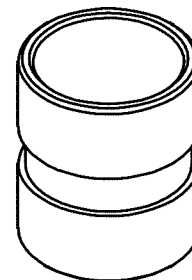
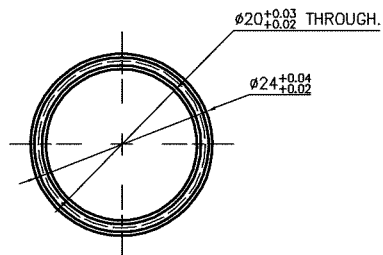

SECTION A-A

NOTES:
1. ALL CHAMFERS TO BE 0.5 X 45°

TITLE:
MINI LATHE
PART-NAME:
TAILSTOCK SHAFT BUSH

DRN NO: LA030900

DRN BY:

DATE: 02-2001

FILE: TAILSTOCK.DWG

REV NO: B

REV BY:

DATE: 08-2001

FINISH:

MATL: BRONZE

SCALE: 1:1

DO NOT SCALE DRAWING

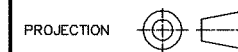

GENERAL MACHINING TOLERANCE

.X \pm 0.20
.XX \pm 0.05
0 TO 250 \pm 0.5
500 & ABOVE \pm 2.0
TIR \pm 0.20
ANGULAR \pm 1/4°



THE HONG KONG
POLYTECHNIC UNIVERSITY
INDUSTRIAL CENTRE

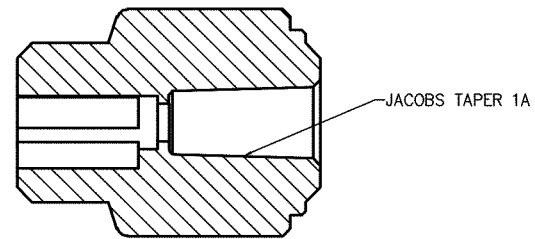
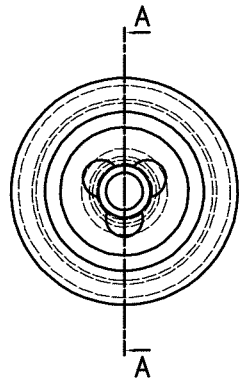
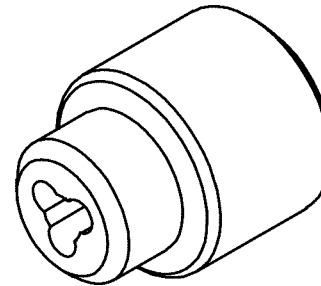
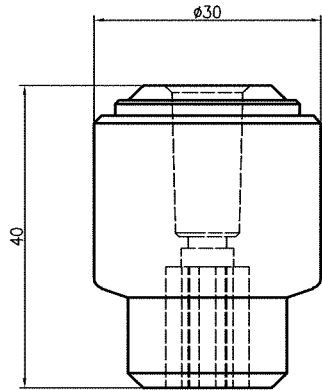

A-A

TITLE:	MINI LATHE
PART-NAME:	DRILL CHUCK
DRN NO:	LA160000
DRN BY:	
DATE:	02-2001
FILE:	TAILSTOCK.DWG
REV NO:	A
REV BY:	
DATE:	04-2001
FINISH:	
MATL:	STANDARD PART
SCALE:	1:1
DO NOT SCALE DRAWING	
PROJECTION	
GENERAL MACHINING TOLERANCE	
.X ± 0.20	
.XX ± 0.05	
0 TO 250 ± 0.5	
500 & ABOVE ± 2.0	
TIR ± 0.20	
ANGULAR ± 1/4°	



THE HONG KONG
POLYTECHNIC UNIVERSITY
INDUSTRIAL CENTRE

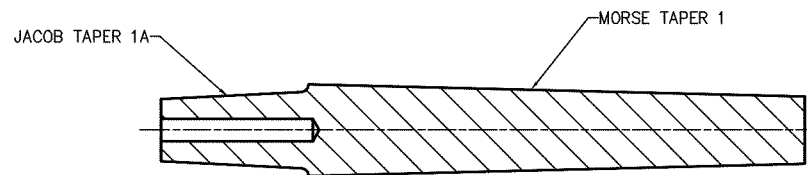
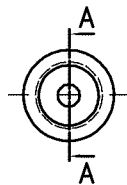
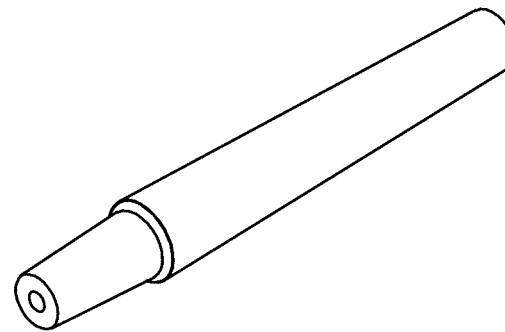
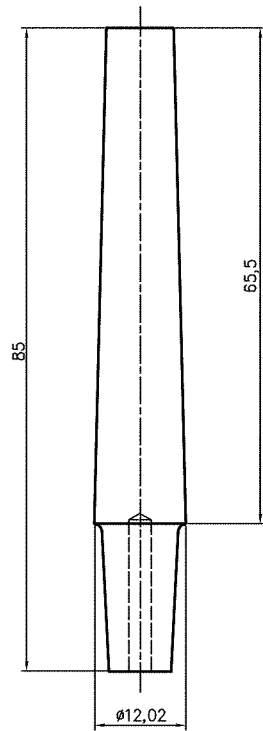

A-A

TITLE:	MINI LATHE
PART-NAME:	J1 TO MT1 ARBON
DRN NO:	LA170000
DRN BY:	
DATE:	02-2001
FILE:	TAILSTOCK.DWG
REV NO:	A
REV BY:	
DATE:	04-2001
FINISH:	
MATL:	STANDARD PART
SCALE:	1:1
DO NOT SCALE DRAWING	
PROJECTION	
GENERAL MACHINING TOLERANCE	.X ± 0.20 .XX ± 0.05 0 TO 250 ± 0.5 500 & ABOVE ± 2.0 TIR ± 0.20 ANGULAR ± 1/4'



THE HONG KONG
POLYTECHNIC UNIVERSITY
INDUSTRIAL CENTRE